

AUTOMOTIVE CURRENT TRANSDUCER

HC2F80-N CLIPS

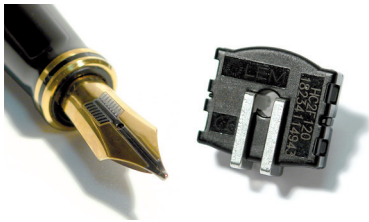

Introduction

The HC2F CLIPS Family is for the electronic measurement of DC, AC or pulsed currents in high power and low voltage automotive applications with galvanic isolation between the primary circuit (high power) and the secondary circuit (electronic circuit).

The HC2F CLIPS family gives you the choice of having different current measuring ranges in the same housing.

Features

- Open Loop transducer using the Hall effect
- Low voltage application
- Unipolar + 5 V DC power supply
- Primary current measuring range from 40 A up to 200 A
- Maximum RMS primary admissible current: defined by busbar to have $T^{\circ} < + 150^{\circ}C$
- Operating temperature range: $- 40^{\circ}C < T^{\circ} < + 125^{\circ}C$
- Output voltage: full ratio-metric (in sensitivity and offset)
- Compact design for PCB mounting.

Advantages

- Excellent accuracy
- Very good linearity
- Very low thermal offset drift
- Very low thermal sensitivity drift
- Wide frequency bandwidth
- No insertion losses.

Automotive applications

- Electrical Power Steering
- Starter Generators
- Converters ...

Principle of HC2F CLIPS Family

The open loop transducers uses a Hall effect integrated circuit. The magnetic flux density B , contributing to the rise of the Hall voltage, is generated by the primary current I_p to be measured. The current to be measured I_p is supplied by a current source i.e. battery or generator (Fig. 1).

Within the linear region of the hysteresis cycle, B is proportional to:

$$B (I_p) = \text{constant} (a) \times I_p$$

The Hall voltage is thus expressed by:

$$V_H = (R_H/d) \times l \times \text{constant} (a) \times I_p$$

Except for I_p , all terms of this equation are constant. Therefore:

$$V_H = \text{constant} (b) \times I_p$$

The measurement signal V_H amplified to supply the user output voltage or current.

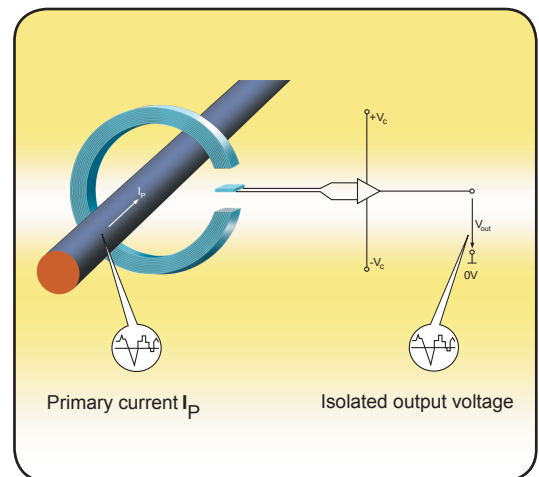

Fig. 1: Principle of the open loop transducer

HC2F80-N CLIPS

Dimensions HC2F xxx-N CLIPS family (in mm.)

Secondary connection

Terminals	Designations
3	Supply voltage + 5 V DC
1	V _{OUT}
2	Ground
E1 to E4	Ground (*)

(*) Only 1 of these 4 pins could be connected

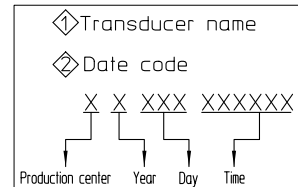
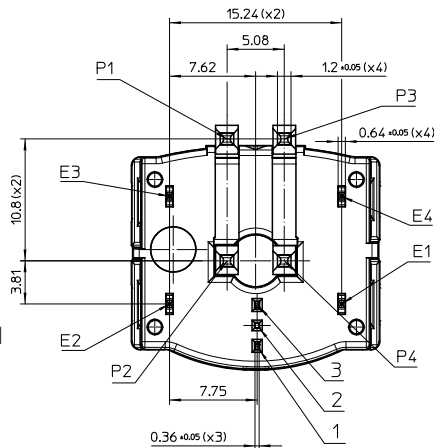

Connection

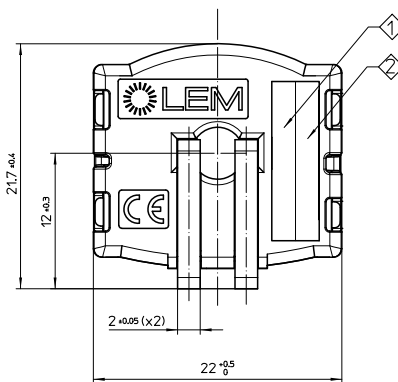
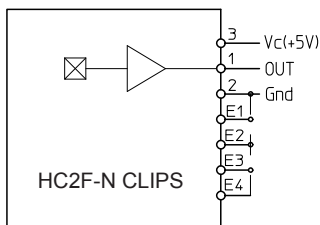

Positive primary current direction

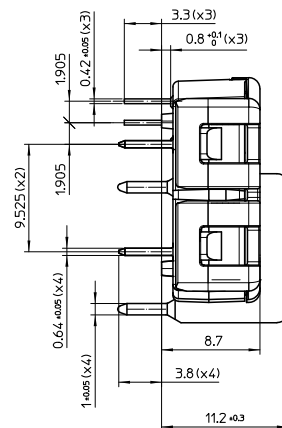

Bill of materials

- Plastic case: PBT GF 30
- Magnetic core: FeSi alloy
- Pins and primary bus bar: Copper alloy tin plated (lead free)
- Mass: 9 g

Remarks

- General tolerance: ± 0.2 mm
- $V_{OUT} > \frac{V_c}{2}$ when I_p flows in the direction of the arrow.

Electronic schematic

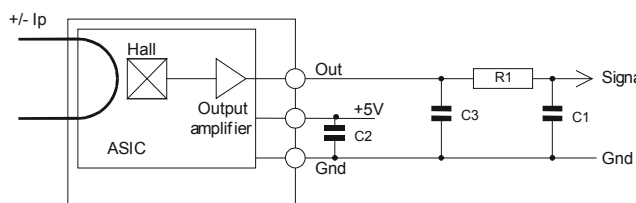

Power supply decoupling capacitor: C2 = 47 nF

EMC protection capacitor: C3 = 4.7 nF

Optional:

High frequency signal noise filter:

R1 > 100 Ω

C1 = defined according to the system frequency bandwidth

HC2F80-N CLIPS

Primary bus bars connected in parallel

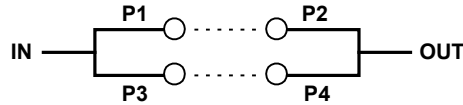

Absolute maximum ratings (not operating)

Parameter	Symbol	Unit	Specification	Conditions
Maximum peak primary current (not operating)	$I_{P\ max}$	A	Defined by busbar to have $T^\circ \leq 150^\circ\text{C}$	
Primary nominal DC or current rms	I_{PN}	A	Defined by busbar to have $T^\circ \leq 150^\circ\text{C}$	
Maximum supply voltage (not operating)	$V_{C\ max}$	V	7	
Secondary maximum admissible power	$P_{S\ max}$	mW	150	
Ambient operating temperature	T_A	$^\circ\text{C}$	$-40 < T_A < 125^\circ\text{C}$	
Ambient storage temperature	T_S	$^\circ\text{C}$	$-40 < T_S < 125^\circ\text{C}$	
Electrostatic discharge voltage	V_{ESD}	V	2000	see page 5/5
Maximum admissible vibration	γ	m.s^{-2}	100	see page 5/5
Rms voltage for AC isolation test 50 Hz, 1 min	V_d	V	1500	
Clearance distance	dCl	mm	1.67	
Creepage distance	dCp	mm	1.8	CTI = 425

Operating characteristics

Parameter	Symbol	Unit	Specification			Conditions
			Min	Typical	Max	
Electrical Data						
Primary current, measuring range	I_{PM}	A	-80		80	@ $-40^\circ\text{C} < T^\circ < 125^\circ\text{C}$
Supply voltage ¹⁾	V_C	V	4.75	5.00	5.25	@ $-40^\circ\text{C} < T^\circ < 125^\circ\text{C}$
Output voltage (Analog)	V_{OUT}	V	$V_{OUT} = (V_C/5) \times (2.5 + 0.025 \times I_p)$			@ $-40^\circ\text{C} < T^\circ < 125^\circ\text{C}$
Sensitivity	G	V/A	0.0245	0.025	0.0255	@ $T_A = 25^\circ\text{C}; V_C = 5.00\text{ V}$
Offset voltage	V_O	V	2.46	2.5	2.54	@ $V_C = 5.00\text{ V}; T_A = 25^\circ\text{C}; I_p = 0\text{ A}$
Current consumption	I_C	mA	-	13.5	20	@ $-40^\circ\text{C} < T^\circ < 125^\circ\text{C}; 4.75\text{ V} < V_C < 5.25\text{ V}$
Load resistance	R_L	K Ω	2	-	-	
Output internal resistance	R_{OUT}	Ω	-	-	10	
Performance Data						
Sensitivity error	ϵ_G	%	-2.0	± 0.7	2.0	@ $T_A = 25^\circ\text{C}; V_C = 5.00\text{ V}; G_{th} = 0.025\text{ V/A}$
Electrical offset	I_{OE}	A	-0.56	± 0.25	0.56	@ $V_C = 5.00\text{ V}; T_A = 25^\circ\text{C}$
	V_{OE}	mV	-14	± 6	14	
Magnetic offset	I_{OM}	A	-1.00	± 0.7	1	@ After excursion to $\pm I_p; T_A = 25^\circ\text{C}$
	V_{OM}	mV	-25	± 17.5	25	
Average temperature coefficient of I_{OE}	TCI_{OEAV}	$\text{mA}/^\circ\text{C}$	-6.0	± 2.8	6.0	@ $-40^\circ\text{C} < T^\circ < 125^\circ\text{C}; V_C = 5.00\text{ V}$
Average temperature coefficient of V_{OE}	TCV_{OEAV}	$\text{mV}/^\circ\text{C}$	-0.15	± 0.07	0.15	
Average temperature coefficient of G	TCG_{AV}	$\%/^\circ\text{C}$	-0.04	± 0.02	0.04	@ $-40^\circ\text{C} < T^\circ < 125^\circ\text{C}; V_C = 5.00\text{ V}$
Linearity error	ϵ_L	% I_p	-1.0	± 0.3	1.0	@ $I_p; V_C = 5.00\text{ V}, T_A = 25^\circ\text{C}$
Response time	t_r	μs	-	15	20	@ $di/dt = 50\text{ A}/\mu\text{s}; I_T = 60\text{ A}$
Frequency bandwidth ²⁾	BW	kHz	20	-	-	@ -3 dB; $I_T = 20\text{ A rms}$
Output voltage noise peak-peak	$V_{no\ p-p}$	mV	-	37	50	@ $T_A = 25^\circ\text{C}; 0\text{ Hz} < f < 1\text{ MHz}$
Output voltage noise rms	$V_{no\ rms}$	mV	-	4	5	@ $T_A = 25^\circ\text{C}; 0\text{ Hz} < f < 1\text{ MHz}$

Notes: ¹⁾ The output voltage V_{OUT} is fully ratiometric. The offset and sensitivity are dependent on the supply voltage V_C relative to the following formula:

$$I_p = \left(V_{OUT} - \frac{V_C}{2} \right) \times \frac{1}{G} \times \frac{5}{V_C} \quad \text{with G in (V/A)}$$

²⁾ Small signal only to avoid excessives heatings of the busbar, the magnetic core and the ASIC.

HC2F80-N CLIPS

Primary bus bars connected in series

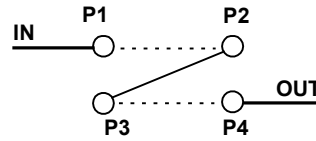

Absolute maximum ratings (not operating)

Parameter	Symbol	Unit	Specification	Conditions
Maximum peak primary current (not operating)	$I_{P\ max}$	A	Defined by busbar to have $T^\circ \leq 150^\circ\text{C}$	
Primary nominal DC or current rms	I_{PN}	A	Defined by busbar to have $T^\circ \leq 150^\circ\text{C}$	
Maximum supply voltage (not operating)	$V_{C\ max}$	V	7	
Secondary maximum admissible power	$P_{S\ max}$	mW	150	
Ambient operating temperature	T_A	$^\circ\text{C}$	$-40 < T_A < 125^\circ\text{C}$	
Ambient storage temperature	T_S	$^\circ\text{C}$	$-40 < T_S < 125^\circ\text{C}$	
Electrostatic discharge voltage	V_{ESD}	V	2000	see page 5/5
Maximum admissible vibration	γ	m.s^{-2}	100	see page 5/5
Rms voltage for AC isolation test 50 Hz, 1 min	V_d	V	1500	
Clearance distance	dCl	mm	1.67	
Creepage distance	dCp	mm	1.8	CTI = 425

Operating characteristics

Parameter	Symbol	Unit	Specification			Conditions	
			Min	Typical	Max		
Electrical Data							
Primary current, measuring range	I_{PM}	A	-40		40	@ $-40^\circ\text{C} < T^\circ < 125^\circ\text{C}$	
Supply voltage ¹⁾	V_C	V	4.75	5.00	5.25	@ $-40^\circ\text{C} < T^\circ < 125^\circ\text{C}$	
Output voltage (Analog)	V_{OUT}	V	$V_{OUT} = (V_C/5) \times (2.5 + 0.05 \times I_p)$			@ $-40^\circ\text{C} < T^\circ < 125^\circ\text{C}$	
Sensitivity	G	V/A	0.049	0.05	0.051	@ $T_A = 25^\circ\text{C}; V_C < 5.00\text{ V}$	
Offset voltage	V_O	V	2.46	2.5	2.54	@ $V_C = 5\text{ V}; T_A = 25^\circ\text{C}; I_p = 0\text{ A}$	
Current consumption	I_C	mA		13.5	20	@ $-40^\circ\text{C} < T^\circ < 125^\circ\text{C}; 4.75\text{ V} < V_C < 5.25\text{ V}$	
Load resistance	R_L	K Ω	2	-	-		
Output internal resistance	R_{OUT}	Ω	-	-	10		
Performance Data							
Sensitivity error	ϵ_G	%	-2.0	± 0.7	2.0	@ $T_A = 25^\circ\text{C}, V_C = 5.00\text{ V}; G_{th} = 0.05\text{ V/A}$	
Electrical offset	I_{OE}	A	-0.28	± 0.12	0.5	@ $V_C = 5.00\text{ V}; T_A = 25^\circ\text{C}$	
	V_{OE}	mV	-14	± 6	14		
Magnetic offset	I_{OM}	A	-0.5	± 0.35	0.12	@ After excursion to $\pm I_p; T_A = 25^\circ\text{C}$	
	V_{OM}	mV	-25	± 17.5	25		
Average temperature coefficient of	I_{OE}	TCI_{OEAV}	$\text{mA}/^\circ\text{C}$	-3.0	± 1.4	3.0	@ $-40^\circ\text{C} < T^\circ < 125^\circ\text{C}; V_C = 5.00\text{ V}$
	V_{OE}	TCV_{OEAV}	$\text{mV}/^\circ\text{C}$	-0.15	± 0.07	0.15	
Average temperature coefficient of G	TCG_{AV}	$\%/^\circ\text{C}$	-0.04	± 0.02	0.04	@ $-40^\circ\text{C} < T^\circ < 125^\circ\text{C}; V_C = 5.00\text{ V}$	
Linearity error	ϵ_L	% I_p	-1.0	± 0.3	1.0	@ $I_p; V_C = 5.00\text{ V}, T_A = 25^\circ\text{C}$	
Response time	t_r	μs	-	15	20	@ $di/dt = 50\text{ A}/\mu\text{s}; I_T = 30\text{ A}$	
Frequency bandwidth ²⁾	BW	kHz	20	-	-	@ -3 dB; $I_T = 10\text{ A rms}$	
Output voltage noise peak-peak	$V_{no\ p-p}$	mV	-	37	50	@ $T_A = 25^\circ\text{C}; 0\text{ Hz} < f < 1\text{ MHz}$	
Output voltage noise rms	$V_{no\ rms}$	mV	-	4	5	@ $T_A = 25^\circ\text{C}; 0\text{ Hz} < f < 1\text{ MHz}$	

Notes: ¹⁾ The output voltage V_{OUT} is fully ratiometric. The offset and sensitivity are dependent on the supply voltage V_C relative to the following formula:

$$I_p = \left(V_{OUT} - \frac{V_C}{2} \right) \times \frac{1}{G} \times \frac{5}{V_C} \quad \text{with } G \text{ in } (\text{V/A})$$

²⁾ Small signal only to avoid excessives heatings of the busbar, the magnetic core and the ASIC.

HC2F80-N CLIPS

PERFORMANCES PARAMETERS DEFINITIONS

Output noise voltage:

The output voltage noise is the result of the noise floor of the Hall elements and the linear I_C amplifier gain.

Magnetic offset:

The magnetic offset is the consequence of an over-current on the primary side. It's defined after an excursion of $I_{P\ max}$.

Linearity:

The maximum positive or negative discrepancy with a reference straight line $V_{OUT} = f(I_P)$.

Unit: linearity (%) expressed with full scale of $I_{P\ max}$.

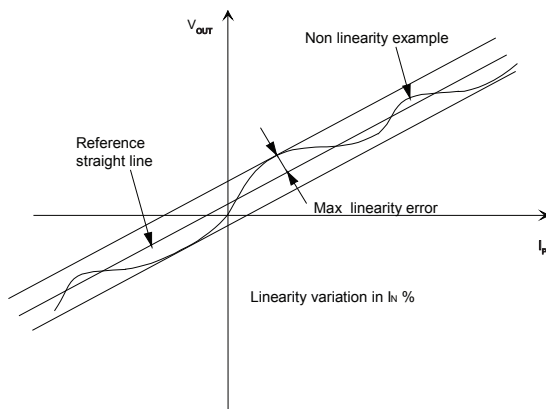

Response time (delay time) t_r :

The time between the primary current signal and the output signal reach at 90 % of its final value

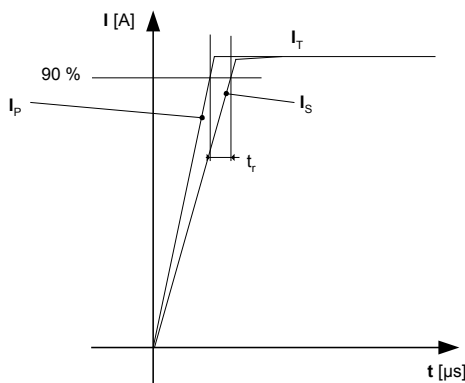

Typical:

Theoretical value or usual accuracy recorded during the production.

Sensitivity:

The Transducer's sensitivity G is the slope of the straight line $V_{out} = f(I_P)$, it must establish the relation:

$$V_{out}(I_P) = V_C/5 (G \times I_P + 2.5) (*)$$

(*) For all symetrics transducers.

Offset with temperature:

The error of the offset in the operating temperature is the variation of the offset in the temperature considered with the initial offset at 25°C.

The offset variation I_{OT} is a maximum variation the offset in the temperature range:

$$I_{OT} = I_{OE\ max} - I_{OE\ min}$$

The Offset drift TCI_{OEAV} is the I_{OT} value divided by the temperature range.

Sensitivity with temperature:

The error of the sensitivity in the operating temperature is the relative variation of sensitivity with the temperature considered with the initial offset at 25°C.

The sensitivity variation G_T is the maximum variation (in ppm or %) of the sensitivity in the temperature range:

$$G_T = (Sensitivity\ max - Sensitivity\ min) / Sensitivity\ at\ 25^\circ C.$$

The sensitivity drift TCG_{AV} is the G_T value divided by the temperature range.

Offset voltage @ $I_p = 0$ A:

Is the output voltage when the primary current is null. The ideal value of V_o is $V_C/2$ at $V_C = 5$ V. So, the difference of $V_o - V_C/2$ is called the total offset voltage error. This offset error can be attributed to the electrical offset (due to the resolution of the ASIC quiescent voltage trimming), the magnetic offset, the thermal drift and the thermal hysteresis.

Environmental test specifications

Name	Standard	Conditions
Low T° storage	IEC 60068 Part 2-1	T° - 40°C / 100 H not connected
Thermal shocks	IEC 60068 Part 2-14	T° - 30°C to 110°C /1000 cycles not connected
Low T° operation at min supply voltage	IEC 60068 Part 2-1	T° - 40°C / 1000 H supply voltage = 4.75 V
Hight T° operation at max supply voltage	IEC 60068 Part 2-2	T° 125°C / 1000 H supply voltage = 5.25 V
Temperature humidity bias	IEC 60068 Part 2-3	T° 90°C / 95 % RH/ 1000 H supply voltage = 5.25 V
Pressure cooker		T° 125°C / 100 % RH, P 0.178 Mpa/100 H supply voltage = 5 V
Mechanical Tests		
Vibration	IEC 60068-2-64	Room T°, acceleration 100 m/s2, frequency 20 to 500 Hz/96 H each axis
Drop test	IEC 60068 Part 2-29	Heigh 750 mm concret floor each directions